

JWB Company

Leak Detection System

Leak Minder[®]™

Model: LDA-1

www.jwbcompany.net

Instruction Manual



Rev.H

Leak Minder[®]™ LDA-1 Leak Detection System Instructions

PLEASE READ ALL INSTRUCTIONS BEFORE INSTALLATION

Checklist of Materials:

- a) Leak detection system in PVC enclosure with alarm horn, strobe light and silence button
- b) Leak detection probe with 16 feet of cable

Operation: The leak detection system will sound a loud speaker/horn and flash a bright red strobe light when a switch signal is detected from the leak detection probe. A test button on the board (LAMP TEST) can be used to test the horn and strobe light.

Leak Detection System Installation

- 1) The leak detection system comes with 2" NPT male process connection that mounts to the top of the tank.
- 2) **FIRST.** Drop the leak detection probe into the vessel that you wish to be monitored for leakage. Feed the cable through the 2" NPT connector and terminate at the "probe" terminal in the center bottom of the board. The are marked +ve (brown wire) and -ve (blue wire). Be sure to terminate the wires to the proper termination.
- 3) **SECOND.** If utilizing the auxiliary relay feature wire in to the terminal marked "Relay". You have a choice of a normally open (NO) or normally closed (NC) contact. Relay is rated at 120 VAC/5A. You will have to make a hole in the enclosure housing to run the alarm relay wires to an external device such as a PLC or control system.
- 4) **THIRD.** Wire in the AC power to the terminals labeled "120VAC". Unit requires 110 VAC primary power.
- 5) **Testing-** The leak detection system has been factory tested for proper operation. However if you wish to test the system before you install the probe simple dip the leak detection probe in a cup of water. The alarm horn and strobe light will activate. To deactivate remove the leak detection probe from the water. You may silence the alarm horn by pressing the "silence button" on the bottom left hand side of the enclosure. The strobe light will continue to flash if liquid is present. Unit automatically resets when liquid is no longer present.
- 6) Should the leak detection probe fail, be disconnected or the interconnection cable is cut the strobe light will illuminate solid, however the horn will not activate.

Leak Detection System Wiring Details

Close Up View

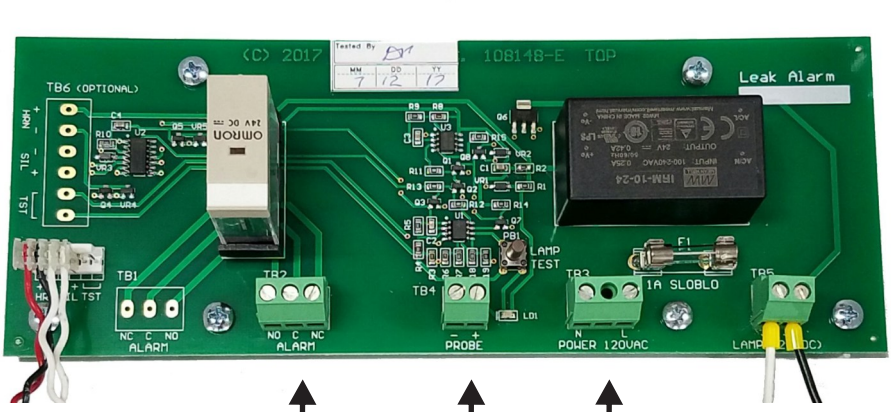

Alarm Contact (optional) Probe AC Power

(Controller Board)



(Probe)

Wiring Diagram

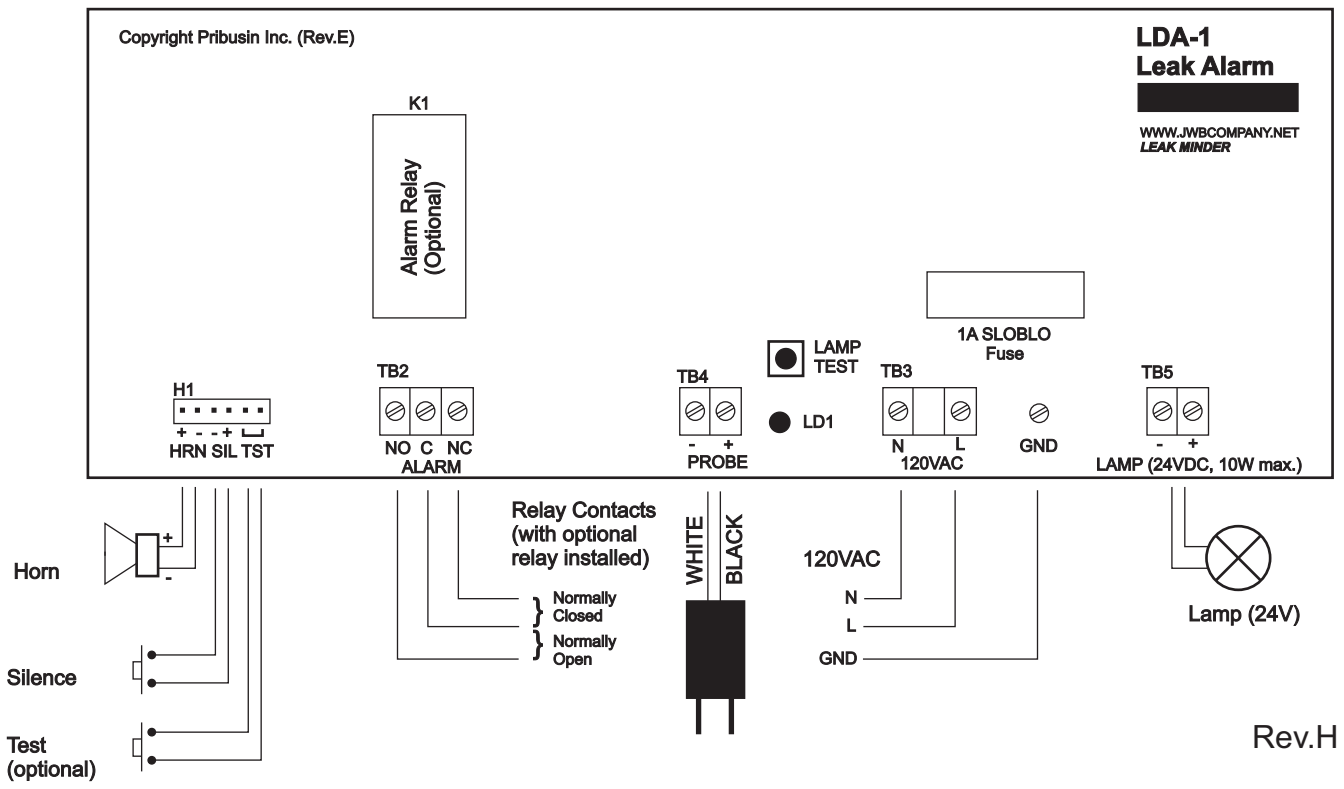

JWB Company

For Support and Service:

65 August Avenue
Wolcott, CT 06716
Phone: (203)879-6959
Fax: (203)879-7299

www.jwbcompany.net
jwbcompany@aol.com

Warranty Policy

JWB Company warrants equipment of its own manufacture to be free from defects in material and workmanship, under normal conditions of use and service, and will replace any component found to be defective, on its return to JWB Company within one year of its original purchase.

An RMA (return material authorization) is required as well as the serial number of the unit.

Transportation charges to and from the factory are the responsibility of the purchaser. JWB Company also assumes no liability, expressed or implied, beyond its obligation to replace any defective component involved. Such warranty is in lieu of all other warranties, expressed or implied.

Specifications

- 1) Output (optional): Form C Contact NO/NC (5A @ 120 VAC)
- 2) Operating Voltage: 115 VAC
- 3) Visual Alarm: Strobe light with red lens (approx. 1 Hz)
- note: lamp will activate solid if probe is not connected or if probe fails
- 4) Audible Alarm: 95 dB, 2900 Hz sounder
- 5) Enclosure: PVC, NEMA 4X weather resistant with 2" NPT male process connection
- 6) Weight: 2.5 lbs without sensor
- 7) Fuse: 1A slo blo type, 5 X 20 mm
- 8) Leak probe: conductance type, 16 feet of cable (longer lengths available) completely potted and sealed for submergence.
- 9) One year factory warranty